

WIND DEFLECTOR MOUNTING INSTRUCTIONS

WD 500 MEDIUM – 22" x 48"
 WD 600 LARGE – 22" x 56"

HARDWARE COMPONENTS:
 4 Utility Straps
 2 Pkgs. Of 4 Mounting Hooks

1. Choose the appropriate suction cup mounting position for your vehicle.
2. Move suction cups to desired position by removing bolts and re-attaching.
3. **Ensure that all bolts on entire wind deflector are fully secure before mounting on vehicle.**

WARNING! READ BEFORE MOUNTING

1. Our wind deflectors are designed to mount onto the majority of vehicles on the market today. The gutter hooks provided fit well on most external or internal rain gutters. There are also some vehicles where this design is not applicable. It is the customer's responsibility to choose and install the correct hook for their respective vehicle and to check for proper fit.
2. Road safety considerations require that all bolts and utility straps should be inspected regularly for tightness when installing the wind deflector for a long period of time. (Not recommended for permanent installation). Travelling at high speeds, high winds, or driving on gravel causes vibrations, which could loosen bolts and straps. We recommend inspecting your deflector every 500 km when driving on pavement and every 200 km when driving on gravel.
3. The utility strap can be cut to an exact length where required. The cut edge should then be sealed by heating lightly with an open flame until the material starts to melt.

Limited Warranty

Icon Technologies Limited warrants all products manufactured by Icon, to be free from defects in material and workmanship under normal usage and service. Icon's obligation under this warranty shall be limited to the replacement of any product which may prove defective under normal usage and service within one year of the invoice date. This warranty shall not apply to products, which have been subject to accident, alteration, misuse, negligence or faulty installation.

All shipping of replacement parts will be to the original destination of purchase from Icon Technologies Limited, and not the end user. Icon Technologies Limited shall pay shipping charges for any such replacement within Canada, but Icon Technologies Limited will not pay for labor costs or other expenses required to replace such defective goods.

Any and all shipping damages must be noted and dealt with the carrier, within 14 days of the invoice date. Icon cannot be held responsible for any damages caused during shipping.



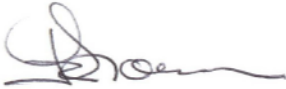

To the extent permitted by law, Icon Technologies Limited does not assume responsibility for loss of use of the product, loss of time, inconvenience, expense for telephone or any other forms of communication, travel, loss or damage to personal property or loss of income. The liability of Icon is expressly limited to the price paid for the defective goods. This warranty is expressly in lieu of all other express warranties.

Icon Technologies Limited neither assumes nor authorizes any person to assume for it, any other liability in connection with the sales of products manufactured by Icon Technologies Limited.

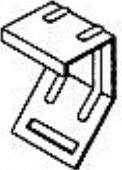
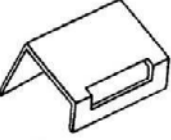

John Loewen
 President,
 Icon Technologies Limited

METHOD OF MOUNTING ON A VEHICLE

Special Order				Included in Box	
					
00932 Hook #2 Gutterless Hook	00933 Hook #3	00934 Hook #4 Gutterless Hook	00935 Hook #5 Gutterless Hook	00936 Hook #6 Gutterless Hook	00647 Hook #8 Universal Hook

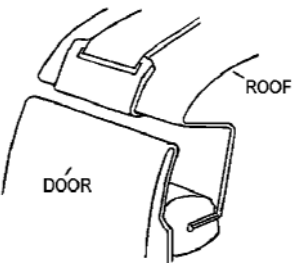
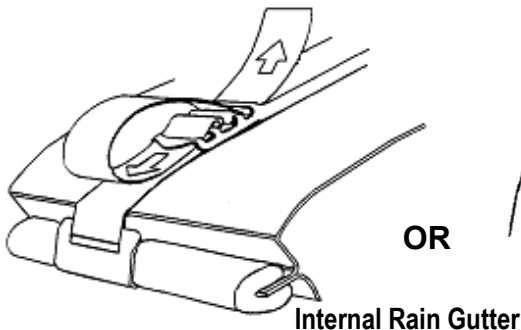

OR



Mounting Instructions

1. Feed the nylon strap through the slot on the side of the wind deflector.
2. Choose appropriate hook for your vehicle according to *Wind Deflector Hook Application Guide* below.
3. Slide the correct hook onto the nylon strap.
4. Feed the end of the strap through the middle of the buckle from the bottom, then through the front of the buckle from the top. After that feed the end of the strap through the back of the buckle from the top. (The strap should now make a loop.)
5. Repeat the above steps for each of the four straps.
6. With vehicle doors open, position the hooks so that they firmly engage the external or internal rain gutters. (Some vehicles do not have rain gutters. The hooks should attach to the cab between the door and the roof.) All four hooks must be used. DO NOT attach hooks to the door or window.
7. Adjust tension on the four straps evenly so that the wind deflector is centered on the roof and hooks are securely attached to the vehicle. BE SURE TO FULLY TIGHTEN THE STRAPS. There should be no slack on the straps if tightened properly.
8. Adjust the angle of the wind deflector so that it is aimed at the top of the trailer you are towing.
9. Tighten the 3-prong wing nut and bolt after adjusting the angle.
10. Your wind deflector is now ready for use!

Wind Deflector Hook Application Guide

For latest hook application guide visit <http://www.IconTechLtd.com/hooks.pdf>

Our hooks fit these and most other late model vehicles. If your vehicle is not listed here, please try the #6 or #8 hooks, which are included in the box. Most newer vehicles use one of these mounting hooks.

Additional hooks can be purchased on our website at <http://www.IconTechLtd.com>

FORD	Icon Hook #	CHEVY/GMC	Icon Hook #
2004-2009 F-150	6	2007 New-2009 Silverado/Sierra	6
1997-2003 F-150	8	1999-2007 Classic Silverado/Sierra	8
1999-2009 F-250 – F-550, Super Duty	8	2007-2009 Avalanche	6
1999-2007 Excursion	8	2001-2006 Avalanche	8
2007-2009 Explorer Sport Trac	6	2007-2009 Suburban/Tahoe/Yukon	6
2001-2005 Explorer Sport Trac	2	2000-2006 Suburban/Tahoe/Yukon	8
1993-2008 Ranger	4	1994-1999 Suburban/Tahoe/Yukon	5
		2002-2009 Trailblazer/Envoy/Rainier	4
		2004-2009 Colorado/Canyon	6
		1998-2009 Express/Savanna Full Size Vans	3
DODGE	Icon Hook #	HONDA	Icon Hook #
2009 Ram 1500, 2500, & 3500	6	2006-2009 Ridgeline	2
2002-2008 Ram 1500	8		
1994-2001 Ram 1500	6		
2003-2008 Ram 2500 & 3500	8		
1994-2002 Ram 2500 & 3500	6		
1997-2004 Dakota	8		
2005-2009 Dakota	6		
JEEP	Icon Hook #	TOYOTA	Icon Hook #
1993-2001 Grand Cherokee	6	2007-2009 Tundra	2
1995-2001 Cherokee	3	1998-2006 Tundra	6
		NISSAN	Icon Hook #
		2004-2009 Titan (No Hook Developed Yet)	N/A